

Pinout Type A

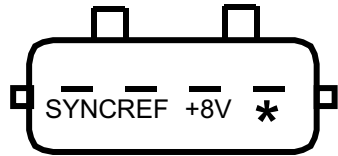

Pinout Type B

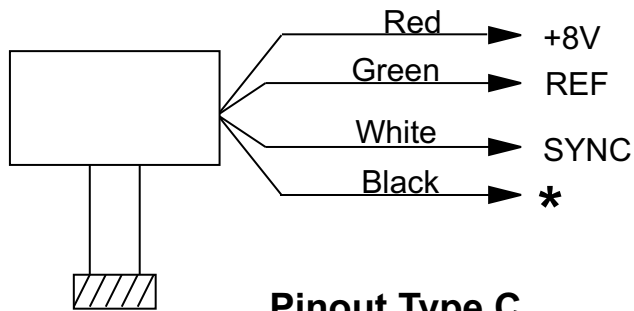

Pinout Type C

* Connect pins together at same Chassis Ground point

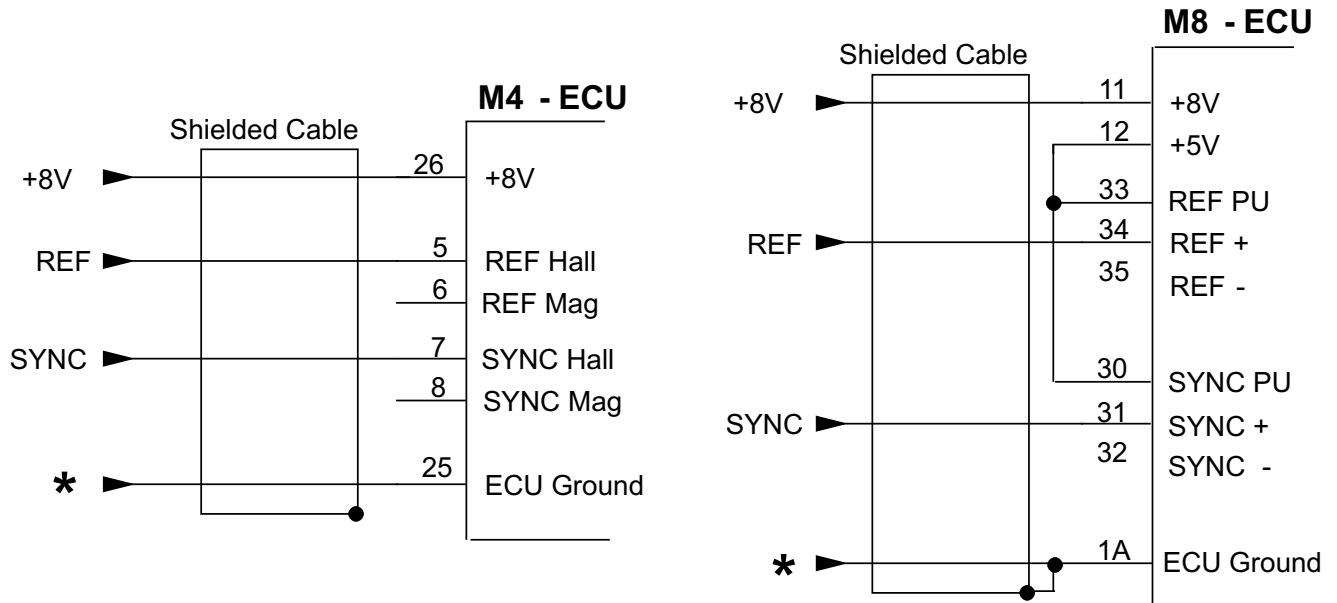

IMPORTANT A special version of the M8 ECU is Required (M8 -HS)

Engine Type		FJ20 VG30	RB26 RB30	SR20	RB20	VH45
Pinout Type		C	A	B	A	?
Setup	M4 Only					
	rfSn	1	1	1	1	1
	SYSn	1	1	1	1	1
	rEF	102	102	102	124	202
	cr t	180	180	180	180	180
criP	60	60	90	90	?	

Note: You must enter the correct number of cylinders for this mode

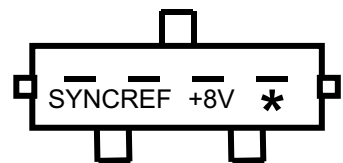

Pinout Type A

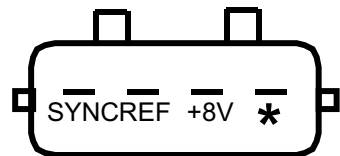

Pinout Type B

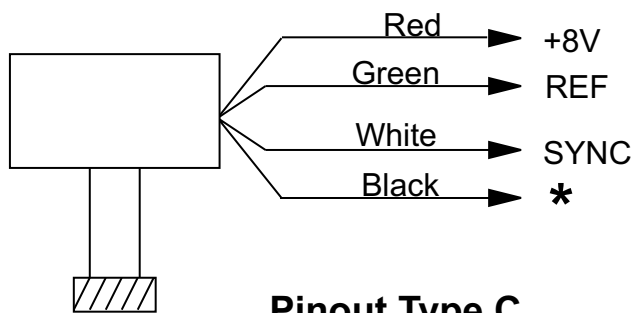

Pinout Type C

* Connect pins together at same Chassis Ground point

M800 (M880) ECU

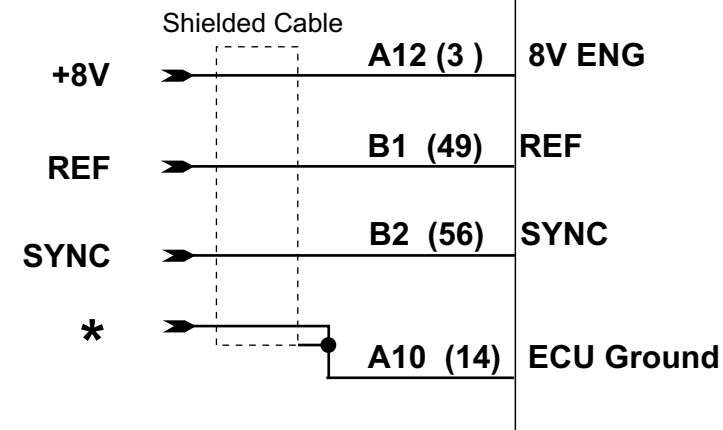

Engine Type	FJ20 VG30	RB26 RB30	SR20	RB20	VH45	
Pinout Type	C	A	B	A	?	

Sensor Setup - REF/SYNC Sensor Setup						
REF Sensor Type	Hall	Hall	Hall	Hall	Hall	
REF Sensor Edge	Rise	Rise	Rise	Rise	Rise	
REF Sensor Filter	0.0	0.0	0.0	0.0	0.0	
SYNC Sensor Type	Hall	Hall	Hall	Hall	Hall	
SYNC Sensor Edge	Fall	Fall	Fall	Fall	Fall	
SYNC Sensor Filter	0.0	0.0	0.0	0.0	0.0	

General Setup - Main Setup						
REF / SYNC Mode	10	10	10	12	20	
Crank Ref Teeth	180	180	180	180	180	
Crank Index Position	60	60	90	90	?	

Note: You must enter the correct number of cylinders for this mode