



PRO-16d
6 CHANNEL
(MOTEC[®] IGNITION EXPANDER)
CAPACITOR DISCHARGE
IGNITION

PLEASE REPORT ANY ERRORS
SALES@MWIGNITIONS.COM

CONTENTS:

1. Installation notes
2. Ignition coil information
3. Mounting dimensions
4. Connections and specifications
5. Wiring diagram
6. EMC compliance

CAUTION

**THIS WIRING DIAGRAM IS
APPLICABLE ONLY TO IGNITION
SYSTEMS WITH THE SERIAL
NUMBER PREFIX STARTING**

54xxxx

**USE OF INCORRECT DIAGRAM
WILL VOID WARRANTY AND
MAY DAMAGE UNIT**

INSTALLATION NOTES

(APPLICABLE TO MOTEC[®] IEX INSTALLATIONS ONLY)

MOUNTING

Do not mount the unit where it will be exposed to water or other liquids and ensure the bottom drain slots are unobstructed. Select a location away from excessive heat and provide a cooling air supply if required. Use soft rubber (approx 40 duro) mounts on all four corners to isolate from strong vibration.

IGNITION LEADS & SPARK PLUGS

Straight metal wire ignition leads radiate electrical interference which may cause erratic operation of nearby electronic devices including the CDI. Carbon suppressed ignition leads are not capable of conducting the CDI energy without damage.

For best performance use spiral wound inductively suppressed metal core ignition leads such as those produced by Magnecor[®]. Where possible use non resistor spark plugs to reduce energy loss.

POWER SUPPLY

FAILURE TO INSTALL THE RECOMMENDED SIZE FUSE WILL VOID WARRANTY

Voltage boosters may limit CDI operation and ignition performance will not increase when operated above 13.8V

WIRING

Connect the CDI directly to the battery with the recommended gauge wire. All coil negative wires must be joined at or in the connector.

Use twisted pair wire for all power and coil connections. To comply with Australian EMC 'C Tick' standards and for ultimate noise suppression use shielded twisted pair wire.

Always use shielded cable for IEX trigger input from ECU.

MODE SELECTION

When using M&W IEX cdi's with Motec® M4/M48 ecu's join the Mode and Signal ground terminals on the main connector. See applicable diagram for specific terminal numbers.

LED INDICATOR

After initially applying power to the CDI the LED will illuminate for approximately 1 second then extinguish to indicate normal operation. The LED will then flash briefly with each consecutive trigger event received.

A repeated double flash of the LED indicates a possible faulty ignition coil, faulty wiring, low supply voltage or damage to the CDI.

TESTING

Due to the complexity of the Motec® Ignition Expander signal a self test mode has been built into the software. By grounding Self test terminal before powering the unit it will sequentially fire all the outputs and flash the LED in sync. To exit the test mode disconnect power from the unit and remove connection to terminal #3. Do not conduct this test without a grounded spark plugs installed and don't touch any of the coil wires.

CAUTION

TO PREVENT IGNITION COIL DAMAGE DO NOT
FIRE THE CDI WITHOUT GROUNDED SPARK
PLUGS INSTALLED AND DO NOT MAKE THE
SPARK JUMP AN EXCESSIVE GAP

IGNITION COILS

COP COILS

COP (coil on plug) coils with built in drivers are not suitable for use with CDI ignitions. Small COP ignition coils may overheat when used in direct fire cdi applications. Inductive COP coils must be wired reverse polarity.

COIL SELECTION

Most inductive ignition coils will work with CDI systems. For best performance they should have very low primary resistance and inductance and a turns ration between 75 and 100 to 1.

For ultimate CDI ignition power use a CDI specific ignition coil such as our CDI COP pencil coils or Ferrite CDI coils.

FERRITE CDI COILS

Be aware when buying ferrite CDI coils from other suppliers who do not have the knowledge or experience to correctly prepare them for automotive use. Due to their fragile nature and poor quality control during manufacture it is easy to experience premature ignition coil failure and engine misfiring unless correctly assembled. All coils prepared by M&W are individually tested before sale.

Note! Ferrite CDI coils are for direct fire ignition only. For high performance distributor applications use either the Crane[®] PS92 or MSD[®] HVC2 coils.

COIL POLARITY

For correct operation inductive ignition coils should be wired with their polarity reversed.

CAUTION!

DAMAGE TO IGNITION COILS MAY OCCUR IF OPERATED WITH AN EXCESSIVE SPARK GAP.

CAUTION!
HIGH VOLTAGE



DISCONNECT POWER BEFORE
WORKING ON UNIT

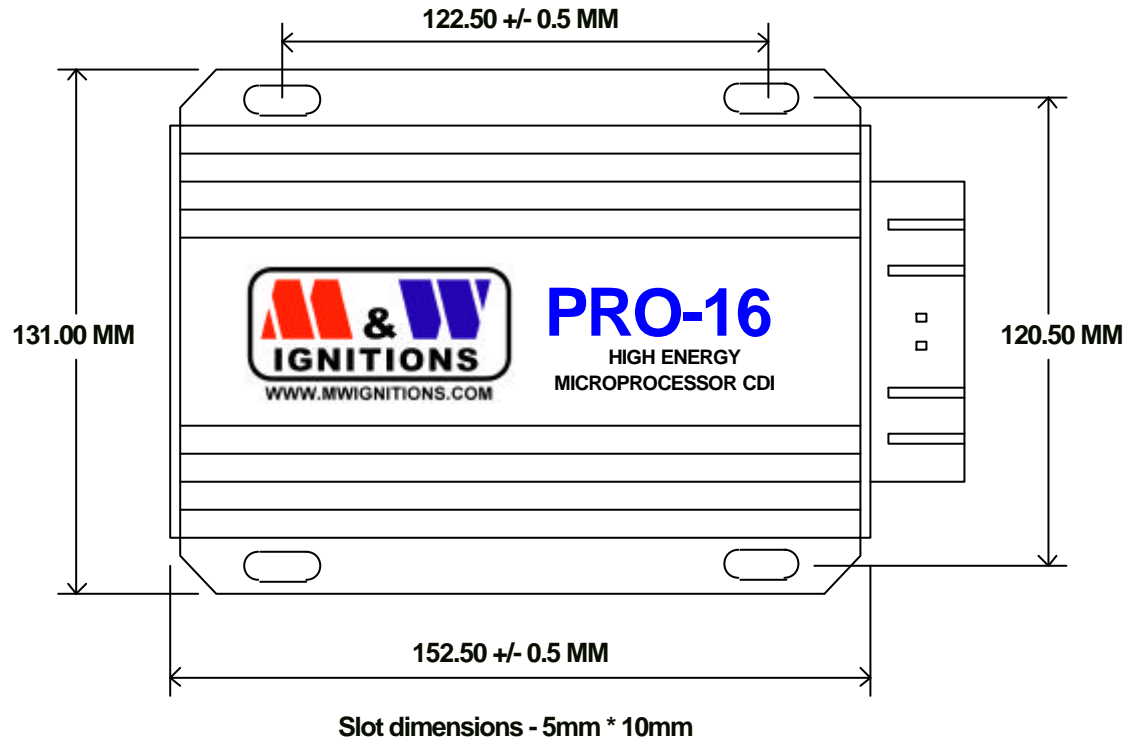

Title			
MOUNTING DIMENSIONS			
Size	Number	Revision	
A4	PRO-16D S3	1.0	
Date:	30-Dec-2008	Sheet 1 of	1
File:	E:\M&W\Pro-16d S3 Mounting dimensions	Drawn By:	M&W

CAUTION!
HIGH VOLTAGE



DISCONNECT POWER BEFORE
WORKING ON UNIT

M & W IGNITIONS

(C)1996 - 2009 M&W IGNITIONS

VIEWED FROM BACK OF CONNECTOR



KEEP ALL INPUTS WELL SEPARATED FROM COIL OUTPUTS

1	+12V (Battery)	13	Ground (Battery)	25	
2	+12V (Battery)	14	Ground (Battery)	26	Ignition switch
3		15		27	
4		16	IEX input	28	
5	Mode	17	Signal ground	29	Self test
6	Tacho	18	Shield	30	
7		19		31	
8		20		32	
9		21		33	
10	Coil 5** +	22	Coil 5 & 6 -	34	Coil 6** +
11	Coil 3** +	23	Coil 3 & 4 -	35	Coil 4** +
12	Coil 1** +	24	Coil 1 & 2 -	36	Coil 2** +

** FIRING SEQUENCE NOT CYLINDER NUMBER

SPECIFICATIONS

Supply voltage = 13.8V DC negative ground
 Operating voltage = +5.5V to +15V
 Maximum supply current = 7.0A
 Power off current < 700uA
 Maximum ignition frequency = 1000 Hz
 Coil primary voltage = 480V
 Spark energy = 115 millijoules @ 700Hz
 Trigger = Motec IEX input
 Tacho = 12V symmetric square wave
 Maximum allowable case temperature = 105°C
 Dimensions = 152L * 110W * 40H
 Weight = 740gm

**FAILURE TO INSTALL FUSE
WILL VOID WARRANTY**

Title			PRO-16 SIX CHANNEL CDI IGNITION
Size	Number	Revision	
A4	Pro-16d S3	1.0	
Date:	30-Dec-2008	Sheet 1 of	1
File:	E:\M&W\Pro16d_S3_1.sch	Drawn By:	M&W

CAUTION!
HIGH VOLTAGE



DISCONNECT POWER BEFORE
WORKING ON UNIT

M & W IGNITIONS

(C)1996 - 2009 M&W IGNITIONS

Note!
Use 20 gauge wire
Twist wires 1 turn in 20mm
Maximum wire length 2M

FAILURE TO INSTALL FUSE
WILL VOID WARRANTY

Note!
Use 20 gauge wire with junction < 100mm
from connector joined to 14 gauge for run
to battery
Twist wires 1 turn in 20mm
Maximum length 2.5M

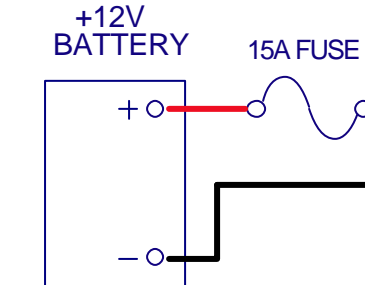

- * Firing order not cylinder number
- ** Join terminals 5 & 17 for M4 / M48 mode

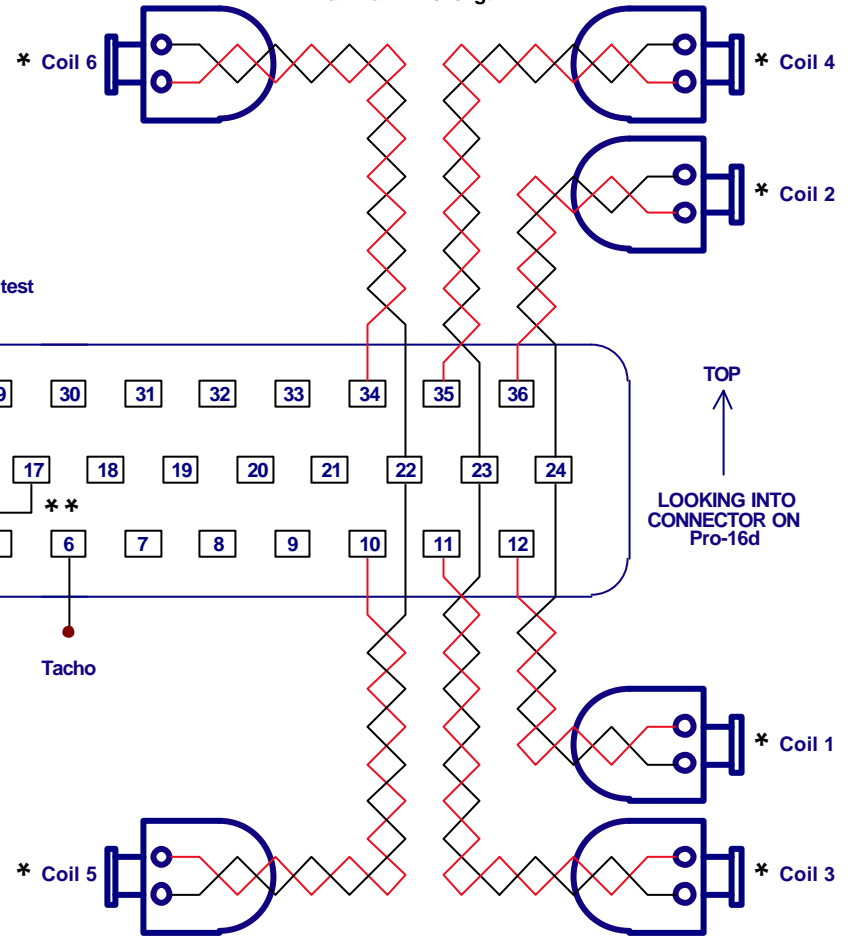
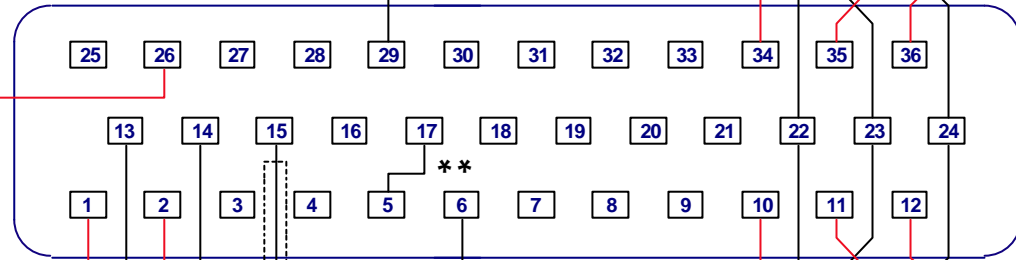

↑ TOP
LOOKING INTO
CONNECTOR ON
Pro-16d

Title			MOTEC IEX INPUT CDI IGNITION		
Size	Number	Revision			
A4	Pro-16d S3	1.0			
Date:	30-Dec-2008	Sheet 1 of	1		
File:	E:\M&W\Pro16d_S3_2.sch	Drawn By:	M&W		

CAUTION!
HIGH VOLTAGE



DISCONNECT POWER BEFORE
WORKING ON UNIT

M & W IGNITIONS

(C)1996 - 2009 M&W IGNITIONS

SHIELDED CABLES REQUIRED
FOR AUSTRALIAN EMC COMPLIANCE

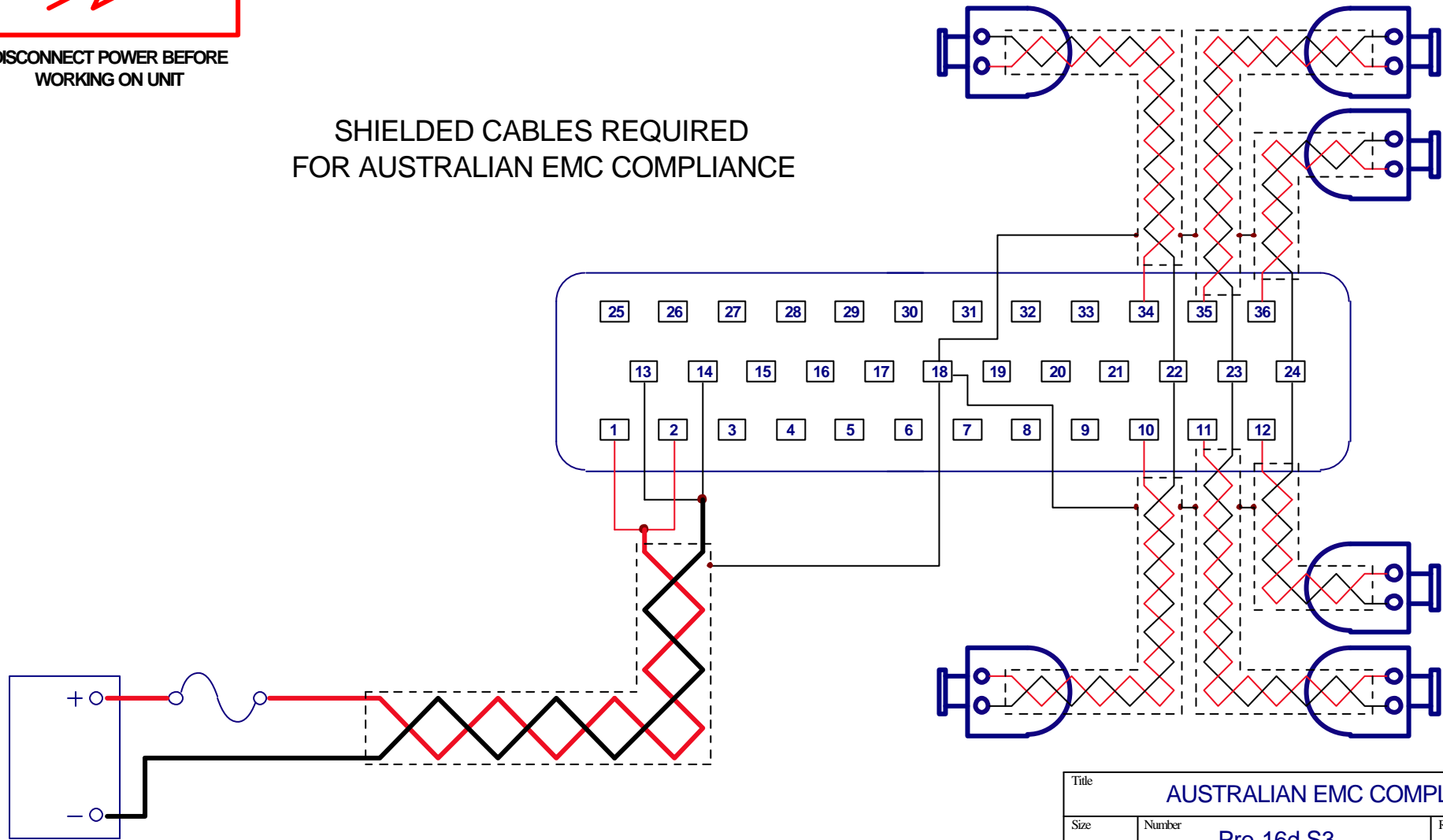

Title			AUSTRALIAN EMC COMPLIANCE		
Size	Number	Revision			
A4	Pro-16d S3	1.0			
Date:	30-Dec-2008	Sheet 1 of	1		
File:	E:\M&W\Pro16d_S3_emc.sch	Drawn By:	M&W		