



MWIGNITIONS.COM

**INSTALLATION INSTRUCTIONS
FOR
PRO-16 S3
6 CHANNEL
CAPACITOR DISCHARGE
IGNITION**

PLEASE REPORT ANY OMISSIONS OR
ERRORS TO SALES@MWIGNITIONS.COM

CONTENTS:

1. Installation notes
2. Ignition coil information
3. Mounting dimensions
4. Connections and specifications
5. 6 channel direct fire ignition
6. 6 coil wasted spark ignition
7. Porsche twin plug wasted spark
8. Mazda triple rotor ignition

CAUTION

**THIS WIRING DIAGRAM IS
APPLICABLE ONLY TO
IGNITION SYSTEMS WITH THE
SERIAL NUMBER PREFIX
STARTING**

38xxxx

**INCORRECT INSTALLATION
WILL VOID WARRANTY**

IMPORTANT **INSTALLATION NOTES**

MOUNTING

Do not mount the unit where it will be exposed to water and ensure the two bottom drain slots are unobstructed. If you have an earlier unit without drain slots mount with connector end low.

Select a location away from excessive heat and provide a cooling air supply where necessary.

If there is a likelihood of strong vibration or the vehicle is stiffly suspended use soft rubber (40 duro) mounts on all four corners to isolate against the vibration.

IGNITION LEADS & SPARKPLUGS

Do not use straight metal wire ignition leads as these will cause electrical interference which may effect the ignition or other electronic devices in the vehicle.

Do not use carbon suppressed ignition leads as the carbon core is not capable of conducting the cdi energy and will quickly become damaged.

For best performance use ignition leads with a spiral wound inductively suppressed metal core such as the Magnecor brand.

Be aware that not all brands of carbon resistor spark plugs are suitable for cdi use and the resistive element may become damaged from the cdi energy. NGK (Q series) and Champion (Z series) manufacture inductively suppressed sparkplugs specifically for high energy applications.

WIRING & POWER SUPPLY

The M&W CDI ignition systems are designed to operate directly from 13.8V. Although the 115mJ Pro series will tolerate small voltage fluctuations it is vitally important that the 250mJ and larger Pro-Drag ignitions have a stable supply which does not drop below 12.5V.

Do not use a power supply above 18V as this may activate the internal over voltage protection.

Do not use a 'voltage booster' as most of them are unable to provide the instantaneous current required by the CDI to recharge correctly.

Connect the unit directly to the battery with the recommended gauge wire.

Twisted pair wire is must be used for all ignition coil and battery connections. Coil negative wires must all be returned to the connector pin and not joined in the harness. To comply with Australian EMC standards and for ultimate noise suppression it is necessary to use shielded twisted pair wire with the shield connected to ground at one end only.

It is very important to have a correctly sized fuse installed in the power supply wiring at all times as this will prevent damage due to over voltage and reversed polarity wiring. If the external fuse blows while the vehicle is running check battery voltage and alternator operation.

Where possible crimp the connector terminals and do not solder them as this will make the wire prone to break at the terminal.

TRIGGER EDGE

(NOT APPLICABLE TO RELUCOR TRIGGER INGITIONS)

The cdi defaults to falling edge ignition, to select rising edge ignition it is necessary to connect the 'Trigger Edge' pin to the 'Signal Ground' pin. The level of the trigger edge input is only sampled when the cdi is initially powered up and therefore can not be changed during operation.

Where the ecu contains an in built igniter or there is an igniter in the trigger circuit between the ecu and cdi it may be necessary to select rising edge ignition as the igniter will invert the trigger signal.

If the incorrect timing edge is selected the ignition timing observed with a timing light will not match that commanded by the ecu and the difference will increase with rpm.

IT IS MOST IMPORTANT TO MAKE SURE THE TRIGGER EDGE ON THE IGNITION SYSTEM IS SET THE SAME AS ON THE ECU.

LED INDICATOR

Once the unit has been switched on the LED on the end of the box will illuminate for approximately 1 second and then extinguish. This indicates that the generator voltage has initialised correctly.

Each consecutive trigger input received, after powering up the unit, will be indicated by a single brief flash.

A repeated double flash of the LED indicates the generator has been unable to reach correct operating voltage. This may be due to faulty wiring, low supply voltage or an internal failure.

**CHECK IGNITION TIMING AFTER INSTALLATION
IS COMPLETE**

IGNITION COILS

CAUTION!

IGNITION COILS WILL BE DAMAGED INTERNALLY IF FIRED WITHOUT A HIGH VOLTAGE RETURN PATH.

If your engine develops a misfire which can not be eliminated by other means try replacing the ignition coil on the suspect cylinder with one that is known to be good.

COP (coil on plug) coils with in built ignition drivers are not suitable for cdi applications. Small COP ignition coils may overheat when used with a cdi system unless wired in parallel for wasted spark applications. COP coils may not have sufficient insulation for use with our high energy Pro-Drag ignition systems

High voltage leakage from the ignition coil secondary to the primary will permanently damage an ignition system. Be aware that large sparkplug gaps, high manifold pressure and high cylinder pressure will significantly increase the coil stress and may cause insulation breakdown.

Most inductive ignition coils will work with CDI system however for best ignition power select one with very low primary resistance and inductance and a turns ration between 75 and 100 to 1 such as the Bosch MEC717.

For best ignition power use a cdi specific ignition coil such as our Ferrite CDI coils. Alternate high quality cdi coils such as the Crane PS92 or MSD HVC2 may also be used.

FERRITE COILS

Be aware when buying ferrite coils from other suppliers as not all companies have the knowledge to correctly prepare them for automotive use. Due to their fragile nature and poor quality control during manufacture it is easy to experience prema ture ignition coil failure and engine misfiring unless correctly assembled. All coils prepared by M&W are individually tested before assembly and sale.

Note! Ferrite coils are only for direct fire applications and must not be used with a distributor.



DISCONNECT POWER BEFORE WORKING ON UNIT

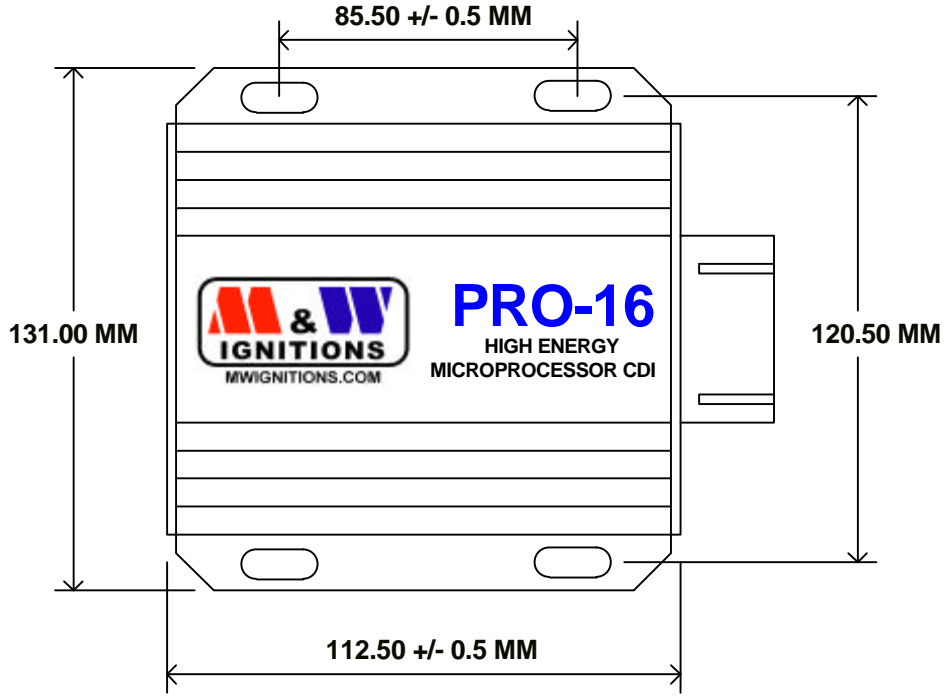

Slot dimensions - 5mm * 10mm

Title				MOUNTING DIMENSIONS	
Size	Number	PRO-16 SERIES 3		Revision	
A4				1.1	
Date:	11-Oct-2007	Sheet 1 of	1		
File:	E:\M&W\Pro16_S3_Mounting dimensions		Drawn By:	M&W	

**CAUTION!
HIGH VOLTAGE**



**DISCONNECT POWER BEFORE
WORKING ON UNIT**

M & W IGNITIONS

(C)1996 - 2007 M&W IGNITIONS

VIEWED FROM BACK OF CONNECTOR



KEEP ALL INPUTS WELL SEPARATED FROM COIL OUTPUTS

1 +12V (Battery)	7 Ground (Battery)	13 Power level
2 +12V (Battery)	8 Ground (Battery)	14 Triggers C & D
3 Triggers E & F	9 Trigger edge	15 Triggers A & B
4 Tacho	10 Signal ground	16 Ignition switch
5 Coils E & F +	11 Coils C & D +	17 Coils C & D -
6 Coils A & B +	12	18 Coils A/C & B/D -

POWER LEVEL SELECTION

105mJ - leave pin #13 disconnected.

150mJ - connect pin #13 to pin #10.

TRIGGER EDGE SELECTION

Falling edge ignition - leave pin #9 disconnected.

Rising edge ignition - connect pin #9 to pin #10.

When triggering this unit of an existing ignition module or an ecu with built in igniters such as the Microtech 'MTX' series it may be necessary to select rising edge trigger.

SPECIFICATIONS

Supply voltage = 13.8V DC negative ground
 Operating voltage = +5.5V to +15V
 Maximum supply current = 6.0A (per unit)
 Power off current < 700uA
 Maximum ignition frequency = 1200/800 Hz (combined)
 Coil primary voltage = 460V/540V
 Spark energy = 105/150 millijoules
 Trigger = 10mA adjustable edge
 Tacho = 12V, 25mA square wave
 Maximum allowable case temperature = 105°C
 Dimensions = 112L * 110W * 40H
 Weight = 570gm (each)

Title			PRO-16 SIX CHANNEL CDI IGNITION
Size	Number	Revision	
A4	SERIES 3	1.1	
Date:	11-Oct-2007	Sheet 1 of	1
File:	E:\M&W\..Pro16_S3_1.sch	Drawn By:	M&W

**FIRING ORDER MUST
ALTERNATE BETWEEN BOXES**



- * See page 1 instructions for trigger edge selection link
- ** Shielded cables required for Australian EMC compliance

**DISCONNECT POWER BEFORE
WORKING ON UNIT**

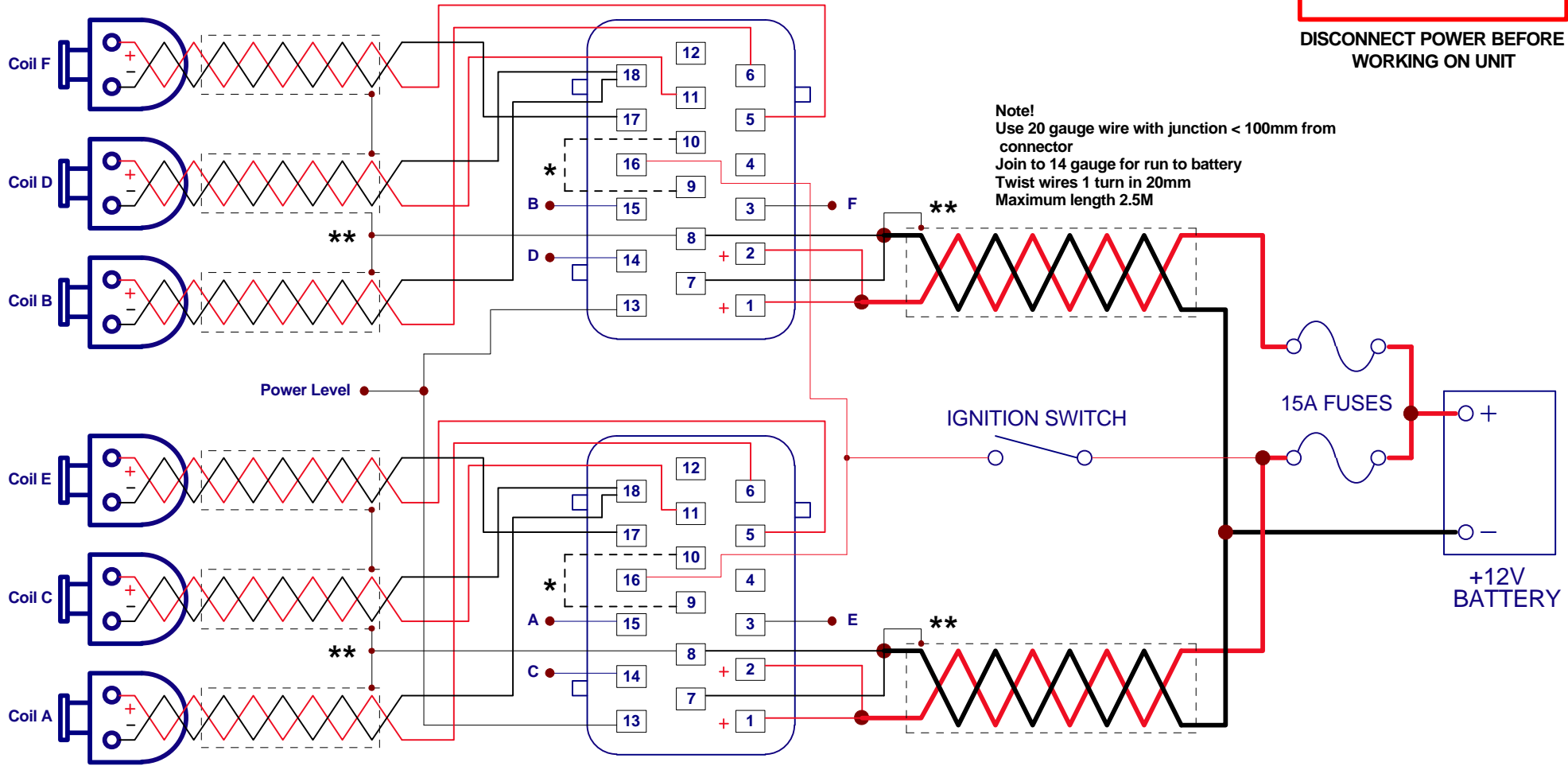

Note!
Use 20 gauge wire with junction < 100mm from
connector
Join to 14 gauge for run to battery
Twist wires 1 turn in 20mm
Maximum length 2.5M

Note!
Use 18-20 gauge wire
Twist wires 1 turn in 20mm
Maximum wire length 2M

Title			6 CHANNEL SEQUENTIAL IGNITION		
Size	Number	Revision			
A4	PRO-16 S3	1.2			
Date:	11-Oct-2007	Sheet 1 of	1		
File:	E:\M&W\Pro16_S3_2.sch	Drawn By:	M&W		

M & W IGNITIONS

(C)1996 - 2007 M&W IGNITIONS

CAUTION!
HIGH VOLTAGE

DISCONNECT POWER BEFORE
WORKING ON UNIT

- * See page 1 instructions for trigger edge selection link
- ** Shielded cables required for Australian EMC compliance

Note!
Use 20 gauge wire with junction < 100mm from connector
Join to 14 gauge for run to battery
Twist wires 1 turn in 20mm
Maximum length 2.5M

Note!
Use 18-20 gauge wire
Twist wires 1 turn in 20mm
Maximum wire length 2M

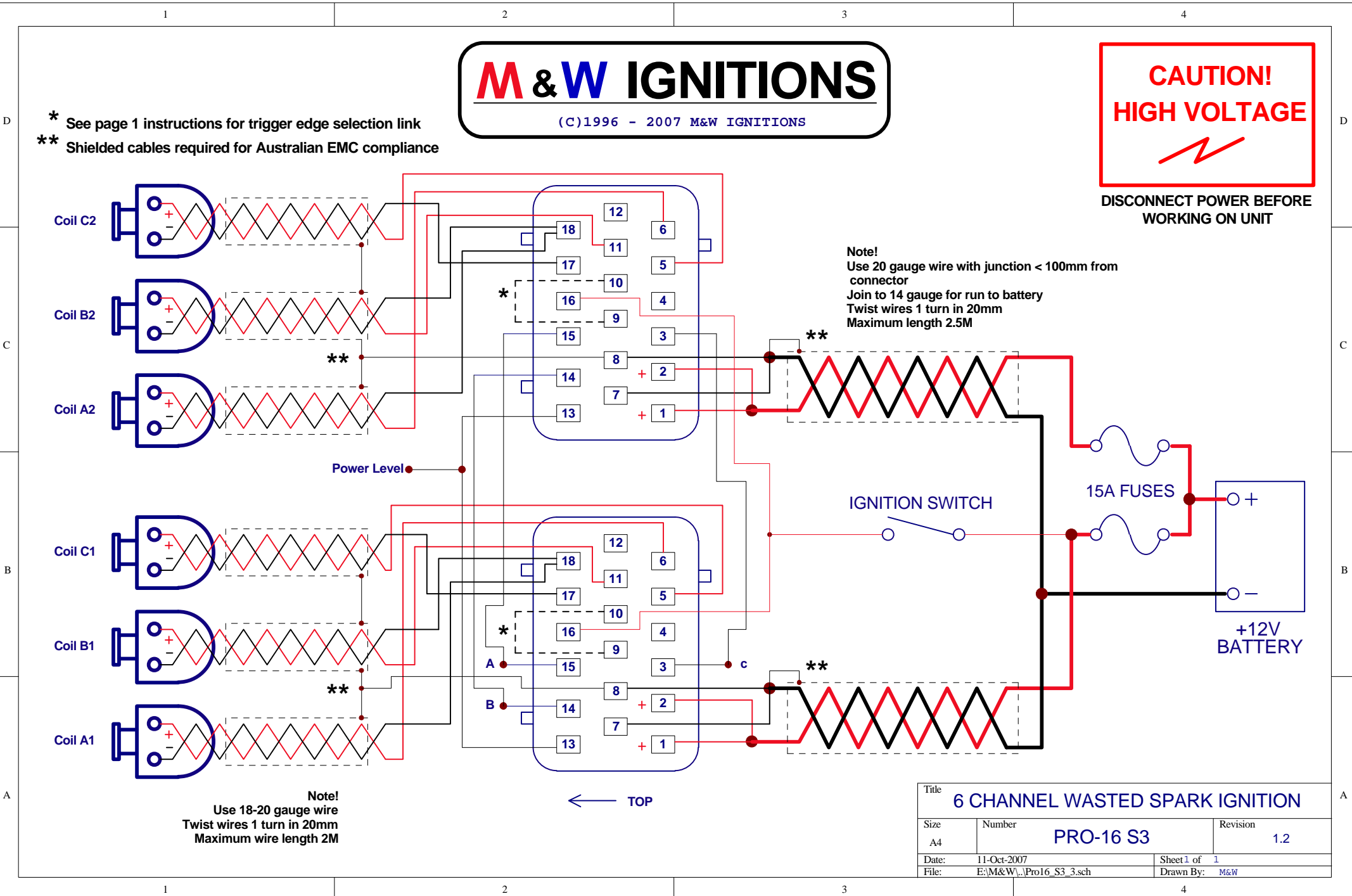

Title			6 CHANNEL WASTED SPARK IGNITION		
Size	Number	PRO-16 S3		Revision	1.2
A4					
Date:	11-Oct-2007	Sheet 1 of	1		
File:	E:\M&W\Pro16_S3_3.sch	Drawn By:	M&W		

M & W IGNITIONS

(C)1996 - 2007 M&W IGNITIONS

CAUTION!
HIGH VOLTAGE

DISCONNECT POWER BEFORE
WORKING ON UNIT

- * See page 1 instructions for trigger edge selection link
- ** Shielded cables required for Australian EMC compliance

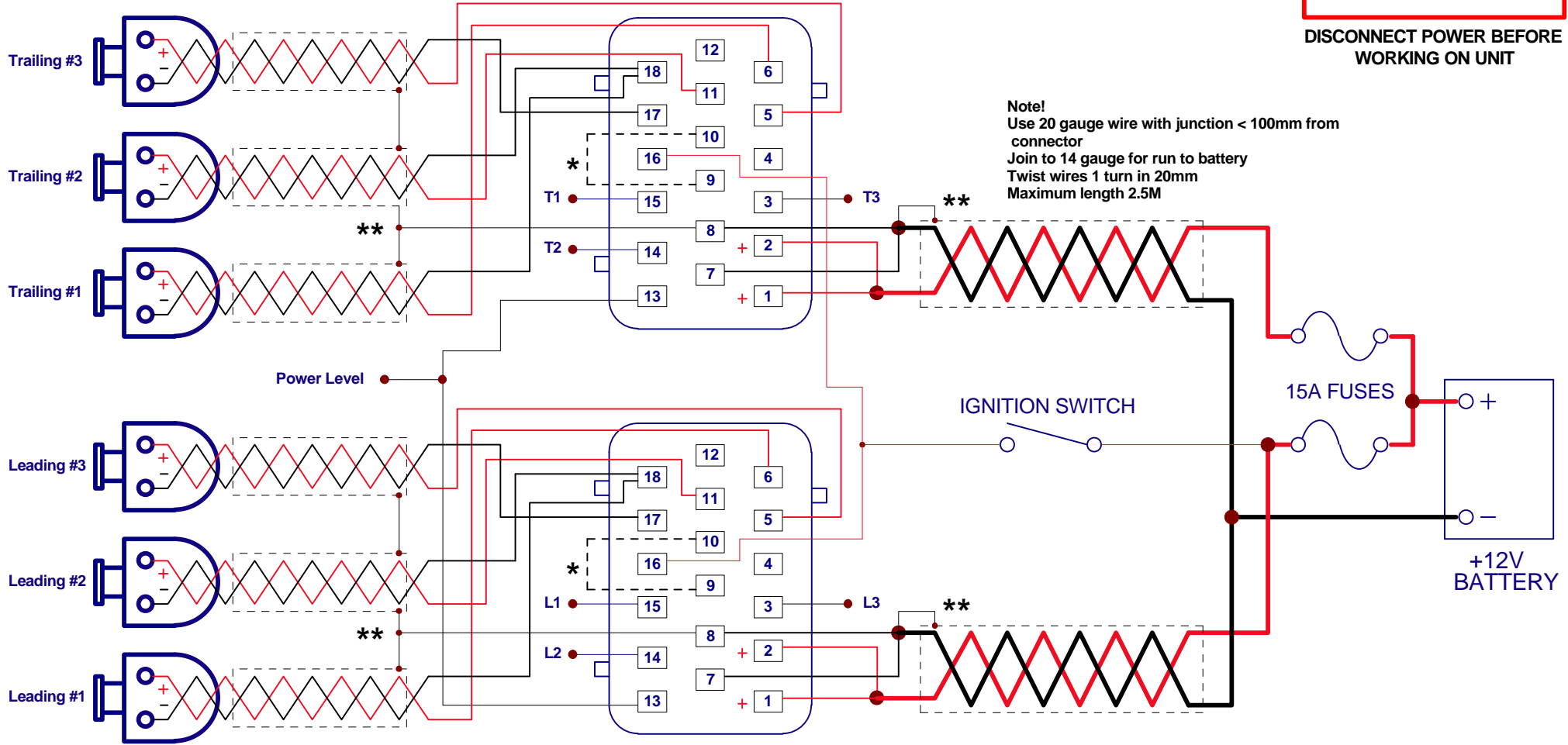

← TOP

Title		
MAZDA TRIPLE ROTOR IGNITION		
Size	Number	Revision
A4	PRO-16 S3	1.2
Date:	11-Oct-2007	Sheet 1 of 1
File:	E:\M&W\Pro16_S3_4.sch	Drawn By: M&W

M & W IGNITIONS

(C)1996 - 2007 M&W IGNITIONS

CAUTION!
HIGH VOLTAGE

DISCONNECT POWER BEFORE
WORKING ON UNIT

- * See page 1 instructions for trigger edge selection link
- ** Shielded cables required for Australian EMC compliance

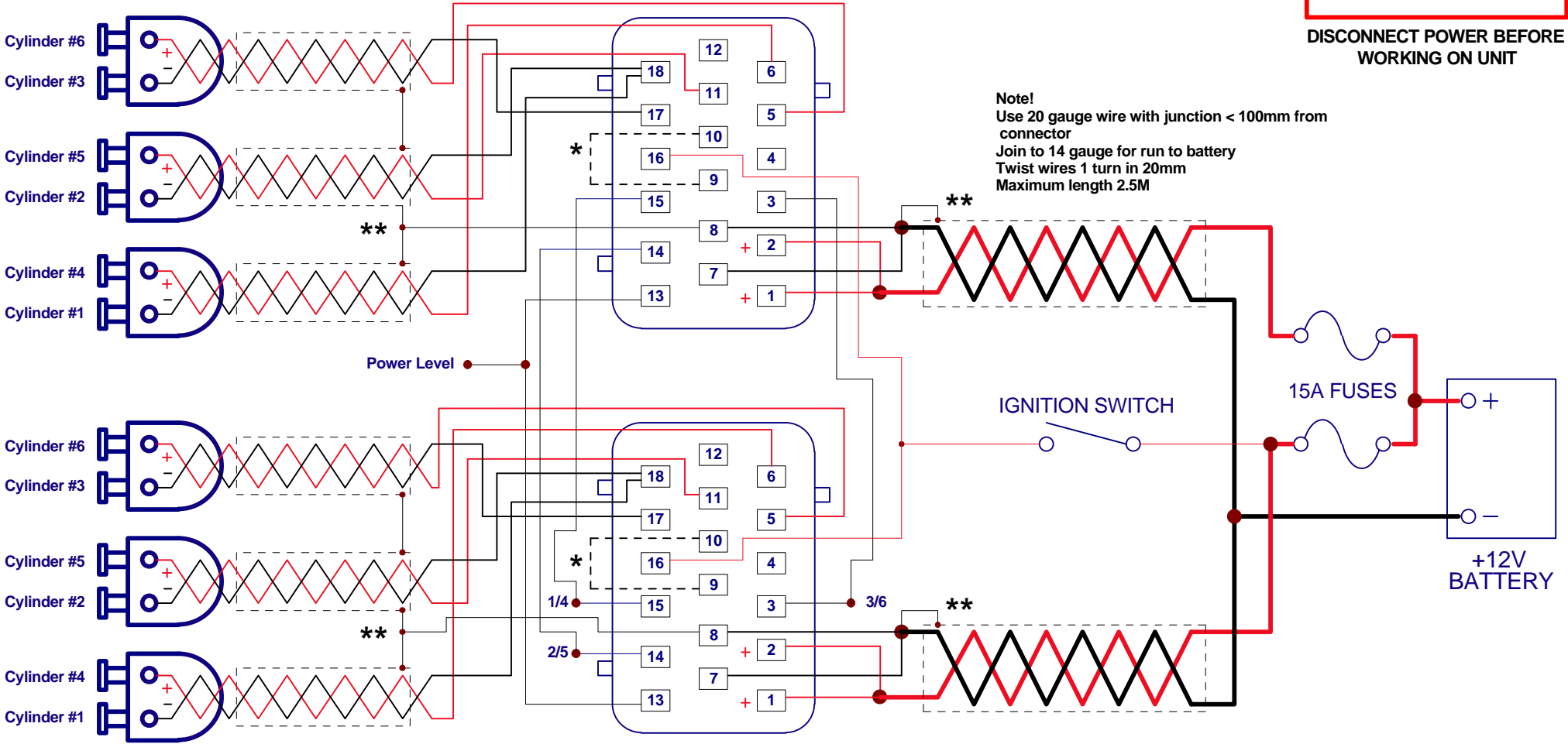

Note!
Use 20 gauge wire with junction < 100mm from connector
Join to 14 gauge for run to battery
Twist wires 1 turn in 20mm
Maximum length 2.5M

Note!
Use 18-20 gauge wire
Twist wires 1 turn in 20mm
Maximum wire length 2M

Title			PORSCHE TWIN PLUG WASTED SPARK		
Size	Number	Revision			
A4	PRO-16 S3	1.2			
Date:	11-Oct-2007	Sheet 1 of	1		
File:	E:\M&W\Pro16_S3_5.sch	Drawn By:	M&W		